

12. Septic tanks and aquaprivies

Septic tanks and aquaprivies both provide primary treatment for wastewater, the only difference between them being the location of the tank in relation to the latrine, and the amount of effluent received by each.

They consist of sealed tanks buried in the ground and receiving household wastewater and excreta, which are partially treated within the tanks.

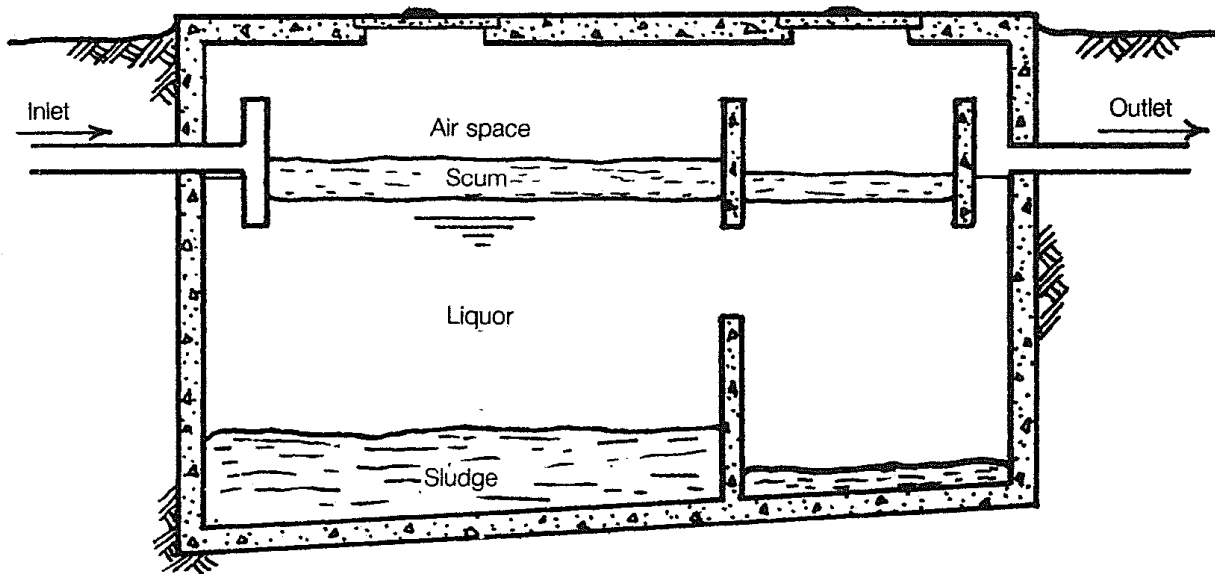

A septic tank is separated from the house and receives waterborne sewage, probably consisting of both toilet waste and household sullage.

An aquaprivy is located directly below a latrine, and water is only needed to maintain the water level in the tank. The amount of wastewater treated will probably be less than for a septic tank, but is likely to be stronger.

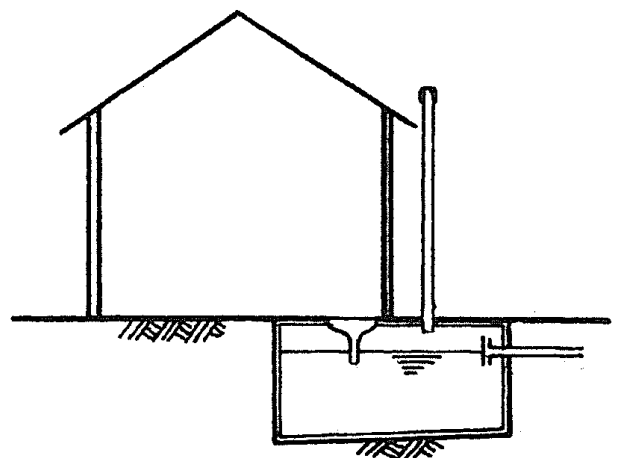
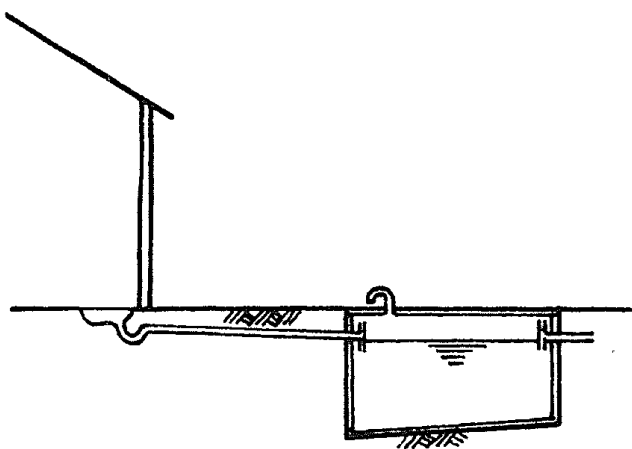

Either may be used to provide partial sewage treatment for individual houses or communal latrines, but they are a comparatively expensive form of sanitation. They are best suited to medium- or low-density housing areas with large plot sizes. Problems arise when they are used in high-density housing areas, and consideration of an adequate means of disposal of the effluent is often neglected.

Septic tanks and aquaprivies

Tank capacity

Tanks should be constructed to have a volume sufficient to allow for the estimated quantities of sludge and scum that will accumulate between desludging operations, and to accommodate the expected wastewater flows for a 24-hour period.

The total liquid storage capacity can be calculated in separate stages.

i) Liquid capacity, $V = Pq$

Where P = number of people expected to use the tank, and q = average daily sewage flow per person.

Approximate flows are:

Septic tank (WC only) 15-40 lcd

Septic tank (full plumbing) 50-120 lcd

Aquaprivy (WC only) 5-18 lcd

ii) Sludge and scum capacity, $W = Pnfs$

Where P = number of people expected to use the tank,

n = number of years between desludging operations,

f = a factor relating to the rate at which the sludge is digested,

and s = the rate at which sludge and scum accumulate.

iii) Total liquid capacity, $C = V + W$, or $C = (1.5)W$, whichever is the greater. It is better to build a tank larger than the minimum size because future needs cannot always be predicted.

Interval between Desludging operations. (Years)	Ambient Temperature		
	More than 20°C throughout the year.	More than 10°C throughout the year.	Less than 10°C during the winter months.
1	1.3	1.5	2.5
2	1.0	1.15	1.5
3	1.0	1.0	1.27
4	1.0	1.0	1.15
5	1.0	1.0	1.06
6ormore	1.0	1.0	1.0

Values of 'f' for calculation of sludge and scum capacity.

Material used for anal cleansing	Flush toilet or latrine wastes only	Both Domestic sullage and toilet wastes
Water, Soft paper	25	40
Leaves, Hard paper	40	55
Sand, Stones, Earth	55	70

Values of 's,' in litres, for calculation of sludge and scum capacity.

Design details

1. Provide a pipe, at either the tank or latrine, to vent waste gases.
2. Ensure the wastewater inlet is below liquid level.
3. Provide a barrier at the outlet pipe to avoid discharge of sludge or scum.
4. Provide access for maintenance and desludging.
5. A slight slope on the tank base makes desludging easier.
6. Tanks having more than one compartment should have openings through dividing walls at liquor level.
7. Never attempt to disinfect or completely empty tanks. New tanks will start to work quickly if a bucket of sludge from a working tank is poured into them.

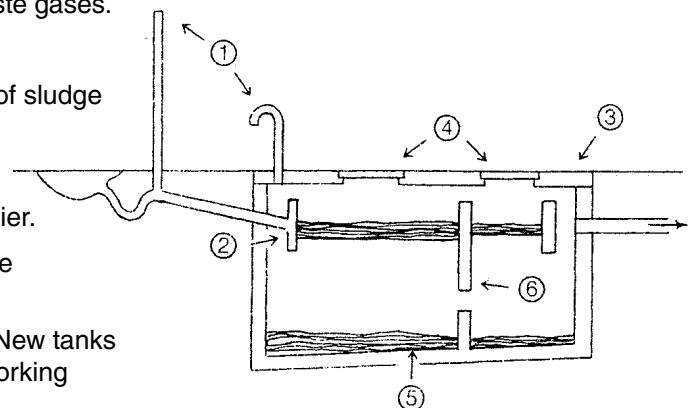

Processes within the tank

1. Separation of solids

Dense material settles to the bottom of the tank where it undergoes digestion to form sludge. Light material rises, floating to the surface to form scum. In between sludge and scum, is a liquid known as liquor, which contains organic and inorganic material in solution and fine particles in suspension which may coagulate and settle out.

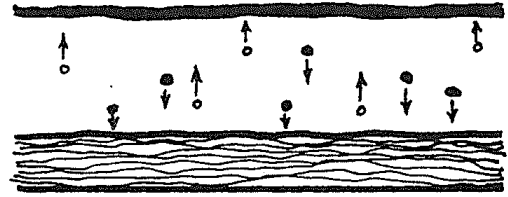

2. Digestion of scum and sludge

These are partially digested anaerobically by bacteria. The waste products, water, methane and carbon dioxide are produced. This causes a reduction in the amount of sludge which forms. Sludge must be periodically removed.

3. Stabilization of the liquor

Organic material remaining in the liquor is partially broken down by anaerobic bacteria.

4. Consolidation of sludge

As material settles to the bottom of the tank, its weight compacts lower layers of sludge. This thickens the sludge and reduces its water content.



5. Mixing of the tank contents

The efficiency of the treatment process is reduced if the tank contents are disturbed, but some mixing is inevitable because of gas production and flow of liquid through the tank.

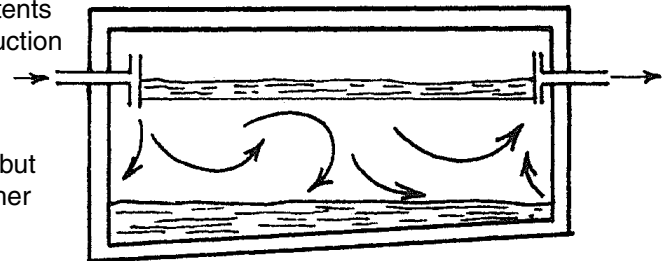

6. Production of micro-organisms

The tank forms a hostile environment for many micro-organisms, but the effluent will contain large numbers of bacteria, viruses and other potentially harmful organisms.

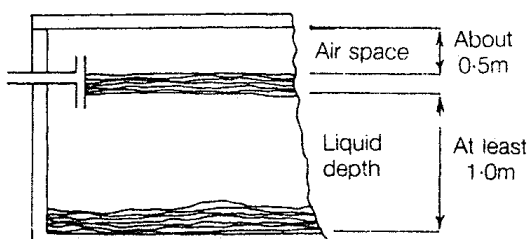
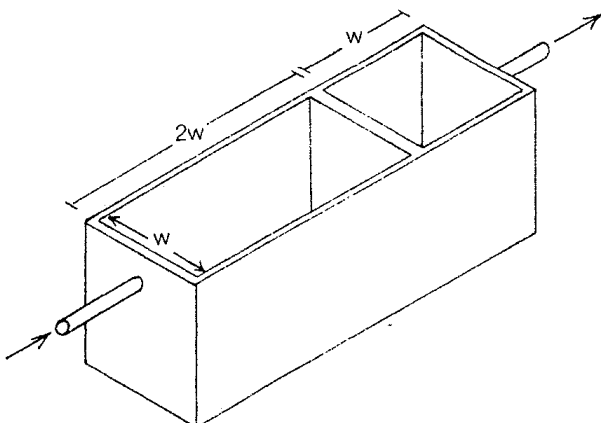
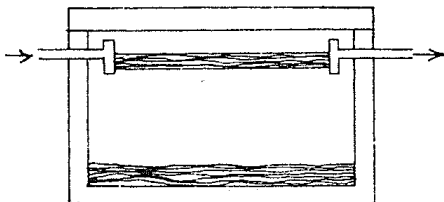

Design considerations

1. Number of compartments

Tanks having a single compartment can operate well, but there is a danger of sludge being disturbed and discharging through the outlet pipe.

Tanks with two compartments are more usual. The first compartment should have a length equal to about twice its width, and the second compartment should have a length equal to its width. Such a design reduces the likelihood of disturbed sludge being carried out of the tank in the effluent.

Tanks with three or more compartments have been suggested but there is little evidence of improved performance resulting from this.

2. Depth

Depth of liquor in a tank should be at least 1.0m, but a depth of 1.5m or more is preferable. There should be an air space of about 0.5m between the liquor and the tank roof.

Septic tanks and aquaprivies

Disposal of effluent from a tank

Careful consideration should be given to the selection of a suitable means of disposal of tank effluent. Possible options are sewers, soak-aways and evapo-transpiration beds.

Soak-aways

Effluent is allowed to filter into the ground. Large areas of land may be needed, and the size of trenches or pits should be estimated by performing soil percolation tests.

Infiltration rates for porous soils are likely to be in the range 10 – 30 litres per day per square metre of sidewall.

If a single pit or trench is used, periodic emptying will be necessary. It is better to provide two pits or trenches which can be used alternatively, allowing the resting pit or trench to recover between periods of use.

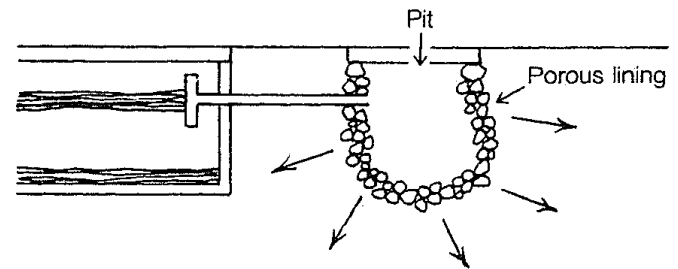
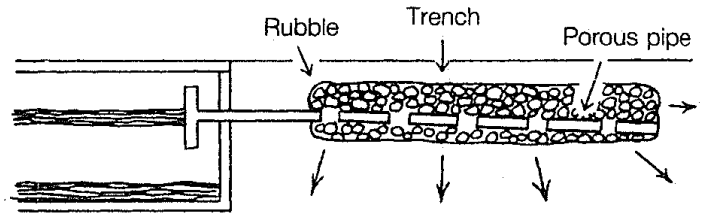

Sewers

These may be either conventional or small bore, but some authorities may prohibit the connection of septic tanks to sewerage networks because of the septicity of the tank effluents.

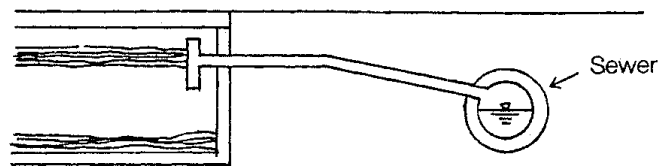

Evapo-transpiration beds

Effluent is evaporated from areas of land on which a steadily growing crop is planted. Large areas of land may be required.

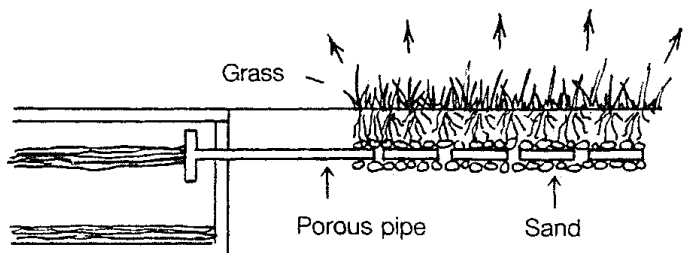

For further reading:

1. Cairncross, S. and Feachem, R.G., *Environmental engineering in the Tropics*, John Wiley and Sons, 1983.
2. Feachem, R. G., et al., *Health aspects of excreta and sullage management*, World Bank, 1981.
3. Mara, D., *Sewage treatment in hot climates*, John Wiley and Sons, 1983.
4. Pickford, J., *The design of septic tanks and aquaprivies*, Overseas Building Note No. 187, September 1980, Building Research Establishment, Watford, England.

Michael Smith, WEDC, Loughborough University of Technology, UK.