



### Integrated Health Monitoring of MNT Enabled Integrated Systems (i-Health)

Andrew Richardson, Lancaster University, Heriot Watt University, QinetiQ, NXP Semiconductors, EPIGEM, UK and Coventor, <http://www.engineering.lancs.ac.uk/microsystems/i-Health.html>

The trend towards higher integration complexities in System-in-Package (SiP) and multi-layer Board technology is now opening possibilities of embedding non-electrical functions such as optics, MEMS and Bio-Chemical based functions with silicon based electronics. Most of these technologies exist but the integration and associated manufacture of these systems places major challenges on the test and reliability validation processes. Applications are in areas such as ambient intelligence, intelligent sensing and medical technologies where fault tolerance and self-test are key requirements (eg. health care, aerospace, implants).

The i-Health project aims to develop research into the possibility of realising a methodology to support low-cost integration of functions able to self-test components and system interconnect during production test, monitor key parameters in mission mode and provide a level of fault tolerance / self-repair. This can be achieved by integrating intelligent health monitoring into highly compact heterogeneous systems like SiP where intrusive monitoring and testing is impossible due to the highly integrated nature of the technology. In particular the i-Health project is investigating solutions to monitor both key fault and degradation behaviour in SiP modules and environmental parameters that correlate with system reliability variations in mission mode. Both sensing and test functions are being developed together with the test control and access infrastructure required. Low-cost built-in self-test solutions such as the bias superposition method that requires only low performance stimulus generation and response analysis functions are being explored for testing the SiP and board based functions. Architectures and testing strategies are also being developed for integrating health monitoring functions into micro and nano technology enabled high performance microsystems based on testing nonelectrical functions with integrated MEMS technologies.

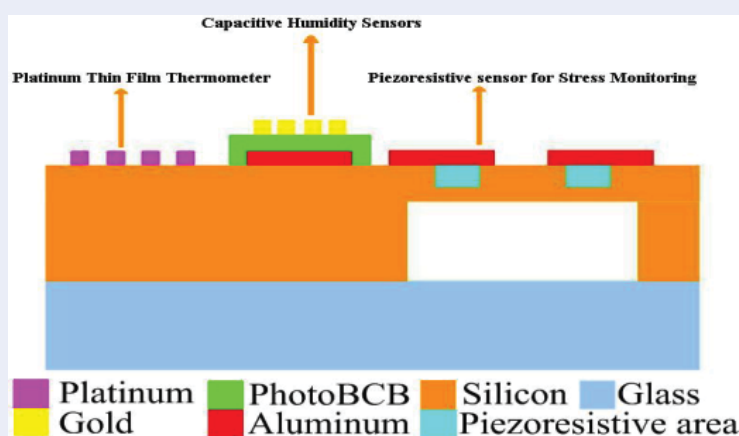



## Standard Project

Miniature sensors for condition/health monitoring of key parameters such as temperature, stress and humidity have been developed. Thin film microsensor arrays have been fabricated for temperature monitoring (1,2,3,4) in microsystems and in process control in laser based manufacturing processes. The sensors have been embedded in substrate assemblies and used successfully in in-situ temperature monitoring in laser assisted polymer bonding process (5). Low cost SAW sensors have been fabricated for humidity monitoring and test in progress to evaluate the performance of the devices. Methods of sensor integration on LiNbO<sub>3</sub> and silicon substrate are being developed.

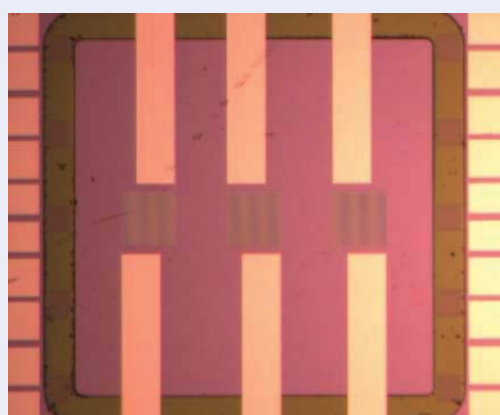

Embedded temperature sensor array under polymer track between glass and silicon substrates for temperature monitoring.

Embedded test work has focused on the application of the bias superposition technique to MEMS based SiP and on Bio-Fluidic Microsystems. The MEMS application has been an accelerometer that targets a SiP implementation via a wafer level packaging process. The target has been to build an embedded test function that supports the work on the IeMRC SiP project reported in (6).

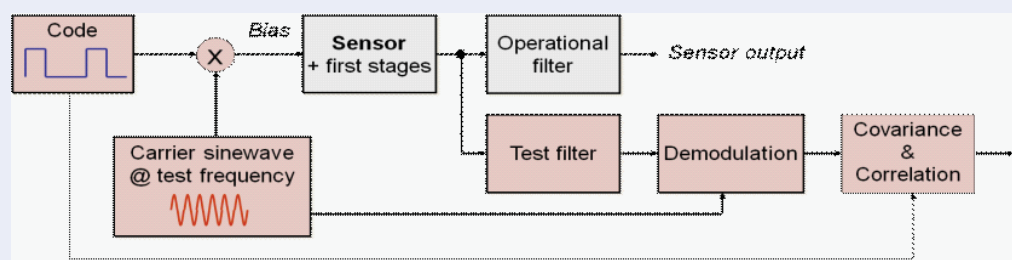

Figure 4 : Application of the Bias Superposition Scheme

The method is illustrated in Figure 4 and involves the injection of an electrostatic stimulus within the physical sensor bandwidth but outside the operational electronic filter bandwidth. It is modulated by a pseudo-random code. The test response is filtered around the test frequency, demodulated and finally covariance and correlation algorithms are applied to extract the signal information that is correlated to the input code (7, 8). The covariance test output measures the sensitivity of the sensor to the stimulus. The signals induced by the measurand or the environment are strongly attenuated. Correlation can be used to check if the sensitivity measurement is corrupted by the environment or not. If not a new test sequence is applied.



## Standard Project

To assess the test output stability the rejection of a perturbing acceleration has been evaluated. The rejection is the worst case measured as 20dB by calculation and 15dB by physical experiments on a shaker (the difference is explained by the simplification in the calculation). The impact of an emulated fault (stimulus amplitude alteration) on the test measurement (covariance) shows the capability to detect a fault. Accuracy better than 5% on the test measurement is demonstrated under stationary vibrations with a spectral density of 13mg/ $\sqrt{\text{Hz}}$  around the test frequency. Non-stationary strong acceleration causing inaccurate test measurement can be detected. On a set of measurements in different environmental conditions, it is verified that there is a relation between the accuracy of the measurement and the correlation output. It is possible to set a threshold (e.g. 0.452) which indicates that the error on the measurement is less than the desired precision (e.g. 5%).

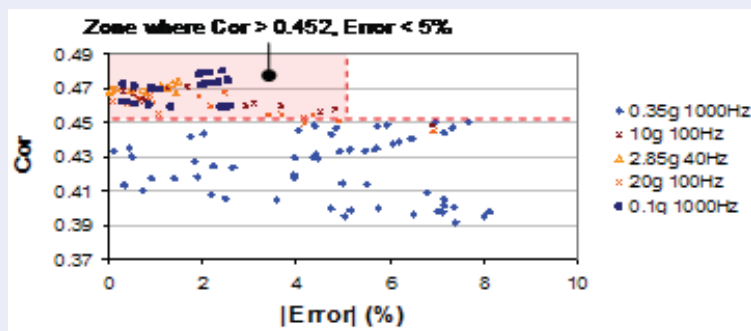

Figure 5 :Relation between the Correlation output and the error

Bio-Fluidics research has built on initial work carried out on the FP6 NoE "Patent-DfMM" with the University of Twente that addressed the need for embedded health and condition monitoring within electronic systems featuring integrated bio-fluidics. Work has progressed in collaboration with QinetiQ focusing on bio-electrode structures, a core component within both droplet and continuous fluidic flow systems for actuation of flow, separation of bio-species (Electrophoresis) and sensing. An online condition monitoring structure for electrode arrays was proposed and applied to a droplet based platform for peptide synthesis in collaboration with MESA+ and the University of Montpellier. Further work has been carried out to address the integration of on-line test and condition monitoring within bio-fluidic instrumentation with both EPIGEM and QinetiQ). This work has focused on an instrument based on microfluidic sample conditioning and delivery to a silicon based photonic detector that targets E-Coli detection in soil. Further work on the electrode structure has focused on oscillation based methods for on-line test and both a practical educational platform together with a 3 day postgraduate course has been developed and funded in May 2009 by the UK IeMRC (Innovative Electronics Manufacturing Centre).

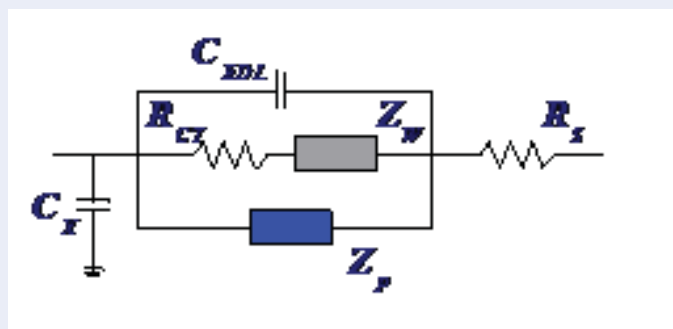

Figure 6 : Bio-electrical model used for degradation detection

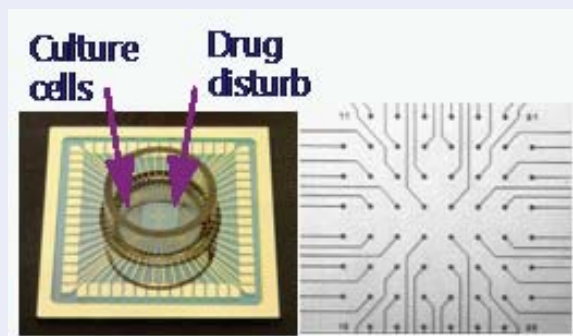

Figure 7 : Electrode demonstrator